



## 2-wire programmable transmitter

### 5331A

- RTD, TC, Ohm, or mV input
- Extremely high measurement accuracy
- 1.5 kVAC galvanic isolation
- Programmable sensor error value
- For DIN form B sensor head mounting



#### Application

- Linearized temperature measurement with Pt100...Pt1000, Ni100...Ni1000, or TC sensor.
- Conversion of linear resistance variation to a standard analog current signal, for instance from valves or Ohmic level sensors.
- Amplification of a bipolar mV signal to a standard 4...20 mA current signal.

#### Technical characteristics

- Within a few seconds the user can program PR5331A to measure temperatures within all ranges defined by the norms.
- The RTD and resistance inputs have cable compensation for 2-, 3- and 4-wire connection.
- Continuous check of vital stored data for safety reasons.

#### Mounting / installation

- For DIN form B sensor head or DIN rail mounting with the PR fitting type 8421.

#### Applications

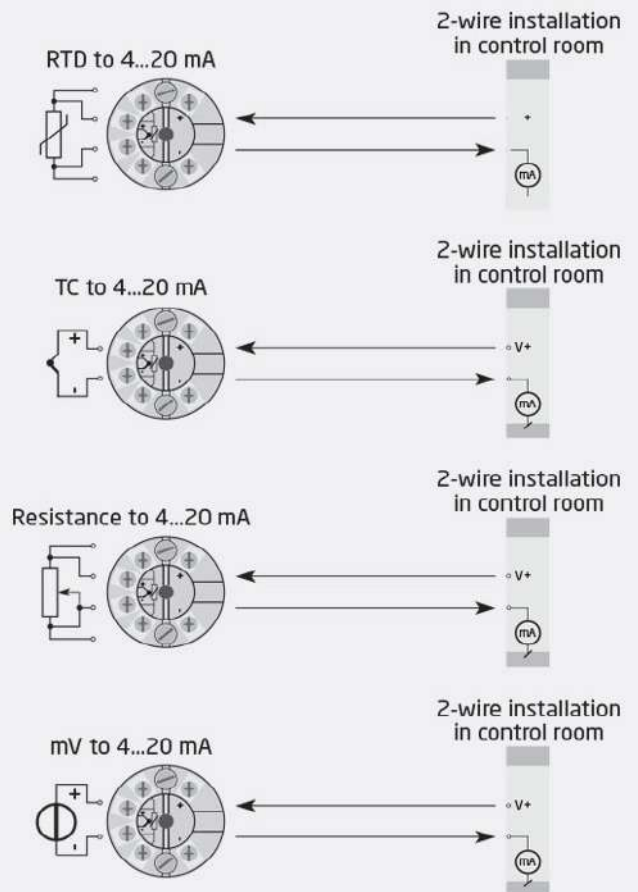

## Order

Type	Version	Ambient temperature	Galvanic isolation
5331	Zone 2 / Div. 2 : A	-40°C...+85°C : 3	1500 VAC : B

## Environmental Conditions

Operating temperature.....	-40°C to +85°C
Calibration temperature.....	20...28°C
Relative humidity.....	< 95% RH (non-cond.)
Protection degree (encl./terminal).....	IP68 / IP00

## Mechanical specifications

Dimensions.....	Ø 44 x 20.2 mm
Weight approx.....	50 g
Wire size.....	1 x 1.5 mm <sup>2</sup> stranded wire
Screw terminal torque.....	0.4 Nm
Vibration.....	IEC 60068-2-6
2...25 Hz.....	±1.6 mm
25...100 Hz.....	±4 g

## Common specifications

### Supply

Supply voltage.....	7.2...35 VDC
Internal power dissipation.....	25 mW...0.8 W

### Isolation voltage

Isolation voltage, test / working.....	1.5 kVAC / 50 VAC
--	-------------------

### Response time

Response time (programmable).....	1...60 s
Voltage drop.....	7.2 VDC
Warm-up time.....	5 min.
Power on to stable output.....	4.5 s
Programming.....	Loop Link
Signal / noise ratio.....	Min. 60 dB
EEPROM error check.....	< 3.5 s
Accuracy.....	Better than 0.05% of selected range
Signal dynamics, input.....	20 bit
Signal dynamics, output.....	16 bit
Effect of supply voltage change.....	< 0.005% of span / VDC
EMC immunity influence.....	< ±0.5% of span
Extended EMC immunity: NAMUR NE21, A criterion, burst.....	< ±1% of span

## Input specifications

### Common input specifications

Max. offset.....	50% of selected max. value
------------------	----------------------------

### RTD input

RTD type.....	Pt100, Ni100, lin. R
Cable resistance per wire.....	5 Ω (max.)
Sensor current.....	Nom. 0.2 mA
Effect of sensor cable resistance (3-/4-wire).....	< 0.002 Ω / Ω
Sensor error detection.....	Yes

### Linear resistance input

Linear resistance min...max.....	0 Ω...5000 Ω
----------------------------------	--------------

### TC input

Thermocouple type.....	B, E, J, K, L, N, R, S, T, U, W3, W5, LR
Cold junction compensation (CJC).....	< ±1.0°C
Sensor error detection.....	Yes
Sensor error current: When detecting / else.....	Nom. 33 µA / 0 µA

### Voltage input

Measurement range.....	-12...800 mV
Min. measurement range (span).....	5 mV
Input resistance.....	10 MΩ

## Output specifications

### Current output

Signal range.....	4...20 mA
Min. signal range.....	16 mA
Load (@ current output).....	≤ (Vsupply - 7.2) / 0.023 [Ω]
Load stability.....	≤ 0.01% of span / 100 Ω
Sensor error indication.....	Programmable 3.5...23 mA
NAMUR NE43 Upscale/Downscale.....	23 mA / 3.5 mA

### Common output specifications

Updating time.....	440 ms
of span.....	= of the presently selected range

## I.S. / Ex marking

ATEX.....	II 3 G Ex nA [ic] IIC T6...T4 Gc, II 3 G Ex ec [ic] IIC T6...T4 Gc, II 3 G Ex ic IIC T6...T4 Gc, II 3 D Ex ic IIIC Dc
IECEx.....	Ex nA [ic] IIC T6...T4 Gc, Ex ec [ic] IIC T6...T4 Gc, Ex ic IIC T6...T4 Gc, Ex ic IIIC Dc
CSA.....	Cl. I, Div. 2, Gp. A, B, C, D T6...T4, Ex nA[ic] IIC T6...T4 Gc
INMETRO.....	Ex ec [ic] IIC T6...T4 Gc, Ex ic IIC T6...T4 Gc, Ex ic IIIC Dc

## Observed authority requirements

EMC.....	2014/30/EU & UK SI 2016/1091
ATEX.....	2014/34/EU & UK SI 2016/1107
RoHS.....	2011/65/EU & UK SI 2012/3032
EAC.....	TR-CU 020/2011
EAC Ex.....	TR-CU 012/2011

## Approvals

ATEX.....	DEKRA 20ATEX0096X
IECEX.....	DEK 20.0059X
CSA.....	1125003
INMETRO.....	DEKRA 23.0009X
DNV Marine.....	TAA0000101
EAC Ex.....	RU C-DK.HA65.B.00355/19